



APD/APDB SERIES SOUND ENCLOSURE

The APD/APDB Series sound enclosure can be used with AEC's APD Series Vacuum Pump. The two-thirds/one-third clamshell design clamps easily around the pump, providing a minimum 15+ dba sound reduction.



APD Series
Sound Enclosure

STANDARD FEATURES

- 13-gauge diamond-plate aluminum construction
- Two-thirds/one-third clamshell design with latching clamps
- 2.75" flat foam, fire retardant, high temperature, oil-resistant insulation
- Resistant to heat and oils
- Baffled air inlet assures maximum attenuation
- Design allows for all-weather installation
- Unit ships fully assembled. Light enough to be lifted over package for installation
- Easy to install
- Easy access for pump service

OPTIONAL FEATURES

- No optional features are available

SPECIFICATIONS

Dimensions, in. (cm)
38 x 40 x 43 (78 cm L x 78 cm W x 215 cm H)

*APD Pump sold separately

DIMENSIONS

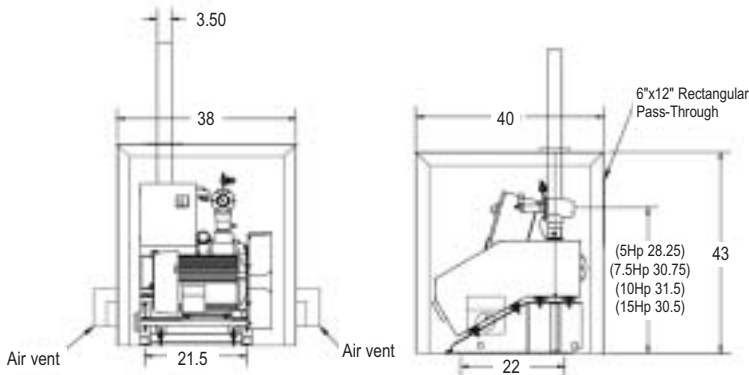

Standard APD Pump Configuration
P/N: A0573898

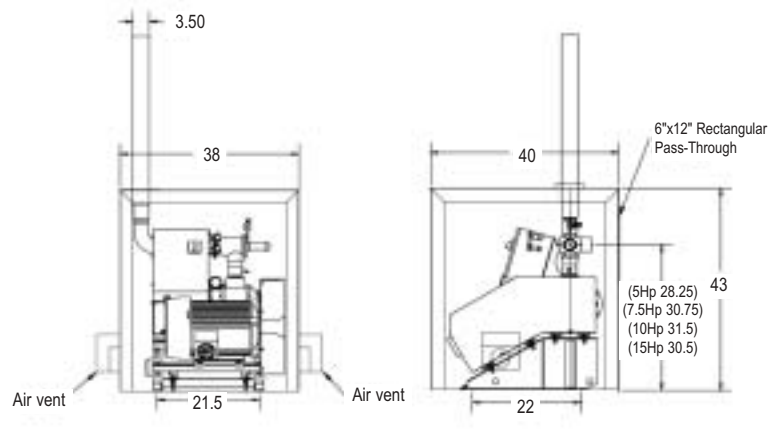

Non-Reversing APDB Pump Configuration
P/N: A0574776