

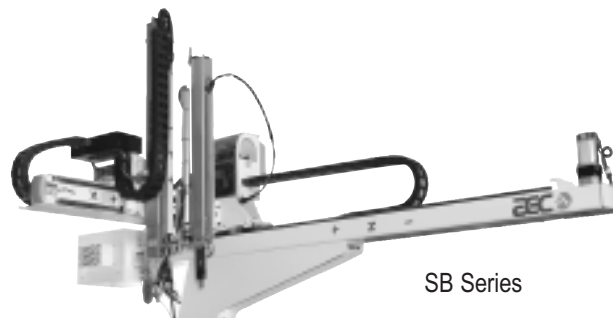

APEX SB SERIES 3-AXIS SERVO DRIVEN TRAVERSING ROBOTS

The SB Servo Driven Traversing Robots feature built-in multi-function programming. Speed, position and timers can be changed during operation. The robot's unique wrist-rotation device enables easy access to the quick-change end of arm tool system. The 3-axis AC brushless servo motors can be independently controlled, and the 3 axes can be synchronized to move to a designated point at the same time with ± 0.1 mm accuracy. Stacking and palletizing functions are standard programs in the state-of-the-art controller.



SB Series

STANDARD FEATURES

- 14 spare inputs and 14 spare outputs
- 1 pressure and 1 vacuum circuit
- Built-in multi-function programming
- Speed, position and timers can be changed during operation
- Wrist flip device with easy to change end of arm tooling using quick change plate system
- The 3 axis AC brushless servo motors can be independently controlled
- 3 axes can be synchronized to move to a designated point at the same time with ± 0.1 mm accuracy
- Stacking and palletizing functions
- Multiple QC function capabilities
- State-of-the-art controller
 - The one-key/one function controller comes with a large LCD screen, providing easy and user-friendly operation.
- Positive servomotor drives with rack and pinion gear on vertical arm
- Standard accessories include a vacuum pad and frame, as well as a quick change system
- Cable guide protection on electrical wires and air hoses
- Unique designed wrist flip device with air shut off pin

OPTIONAL FEATURES

- Additional vacuum circuit (total of 2)
- Additional pressure/grip circuit (circuit only, no gripper/nipper) (total of 2)
- A-axis wrist rotate
- Additional end of arm tooling quick change system
- Telescopic vertical arm for overhead clearance issues
- Sub-arm configurations for 3-plate mold applications

APEX SB SERIES 3-AXIS SERVO DRIVEN TRAVERSING ROBOTS

AUTOMATE

SINGLE STAGE SINGLE ARM SPECIFICATIONS (MM)

Model	B	C	D	E	F	G	H	I	K	L	N
SB-700	90	130	370	810	180	150	1000	1638	2546	1472	550
SB-900	90	130	370	930	180	150	1120	1876	2786	1672	670
SB-1200	90	130	370	1050	180	150	1240	2116	3026	1972	790

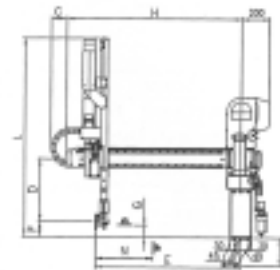

Single-Arm

SINGLE-STAGE SUB-ARM SPECIFICATIONS (MM)

Model	B	C	D	E	F	G	H	I	K	L	N	P	Q
SB-700S	90	130	370	810	180	150	1000	1636	2546	1472	400	170	1510
SB-900S	90	130	370	930	180	150	1120	1876	2786	1672	520	170	1710

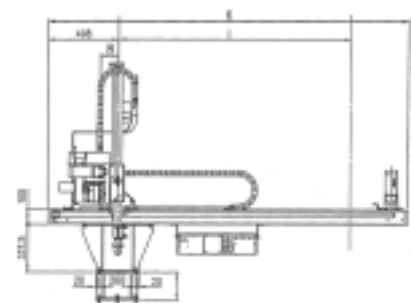

Single-Arm and Sub-Arm

TELESCOPIC SINGLE ARM SPECIFICATIONS (MM)

Model	B	C	D	E	F	G	H	I	K	L	N
SB-700T	69	190	410	817	140	110	1000	1656	2546	1200	520
SB-900T	69	190	410	937	140	110	1120	1896	2786	1300	640
SB-1200T	69	190	410	1057	140	110	1240	2136	3026	1450	760

TELESCOPIC SUB-ARM SPECIFICATIONS (MM)

Model	B	C	D	E	F	G	H	I	K	L	N	P	Q
SB-700TS	69	190	410	817	140	110	1000	1656	2546	1200	335	195	1155
SB-900TS	69	190	410	937	140	110	1120	1896	2786	1300	455	195	1255
SB-1200TS	69	190	410	1057	140	110	1240	2136	3026	1450	542	226	1405

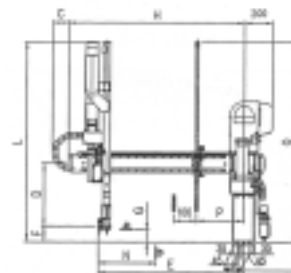

Sub-Arm

Model		Dry Cycle (sec.)		I.M.M. Range (tons)	Stroke (mm)					Max. Payload (kgs)		Net Weight (kgs)	Comp. Air Pressure
		Take-Out	Cycle		Strip		Vertical		Traverse	main	sub		
					main	sub	main	sub					
SB-700	Single-stage, single arm	1.2	9	80-200	550	--	700	--	1636	6	--	230	5kg/cm ²
SB-700S	Single-stage, sub arm				400	100		750			3	240	
SB-700T	Telescopic, single arm				520	--		--			--	250	
SB-700TS	Telescopic, sub arm				335	100		750			3	260	
SB-900	Single-stage, single arm	1.3	10	200-450	670	--	900	--	1876	6	--	235	
SB-900S	Single-stage, sub arm				520	100		950			3	250	
SB-900T	Telescopic, single arm				640	--		--			--	260	
SB-900TS	Telescopic, sub arm				455	100		950			3	270	
SB-1200	Single-stage, single arm	1.4	11	450-650	790	--	1200	--	2116	6	--	240	
SB-1200T	Telescopic, single arm				760	--		--			--	265	
SB-1200TS	Telescopic, sub arm				542	100		1250			3	280	

Power Source: AC 220V Single Phase