



DD SERIES DIGITAL DOSING SYSTEM

The DD Digital Dosing System offers precise feeding for almost any plastics machine, whether your application is injection molding, blow molding, or extrusion. The DD 2 dosing unit offers the ability to use dual additives at different rates. The DD dosing unit uses a variable speed DC drive motor and a correctly sized dosing disc to precisely feed powder or pellet additives, at the set rate, into the throat of the processing machine. Precision design and closed loop control ensures high accuracy to setpoint.



DD 1 Series Digital Dosing System

STANDARD FEATURES

- Disc style feeder module to dose pellets, microbatch, granulate or powders (specify disc size)
- 0-12 RPM variable speed, closed loop drive
- Choice of several styles and sizes of discs for precise additive feeding
- Clear plastic additive hopper with fill cover
- Quick disconnect additive hopper for "off the machine" cleanout/material change
- 2" diameter material feed tube with 6" square mounting flanges (top and bottom)

OPTIONAL FEATURES

- Disc style feeder module to dose pellets, microbatch, granulate or powders (please specify)
- Spare station for immediate changeover for pellets or powders
- Optional motor speeds
- Optional hopper capacities
- Audible alarm
- Alarm light
- Low level sensors
- Hopper loaders for automatic refill
- Special voltage
- Intermediate hoppers for main component side
- Larger base piece for larger processing machines (3" or 4")

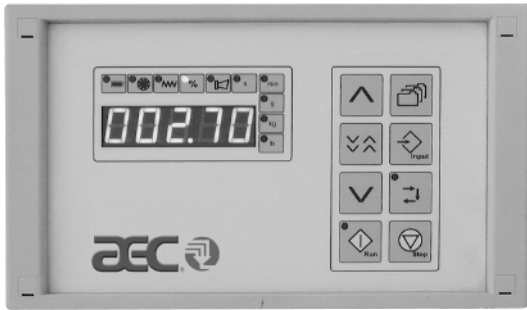

CONTROL FEATURES

Available for either extrusion or injection molding machines, the controller automatically calculates calibration values and allows for direct input of desired percentages. The controller features user-friendly icons and a 5 digit LED display that shows additive consumption. It stores up to 10 recipes, with memory backup for recipe and data storage.

- Dry contact signal input and dry contact alarm output
- Input for level probe for both raw material and additives
- IP64 shielding
- Short circuit proof outputs
- Operates between 32 to 122°F (0 to 50°C)
- Operating voltage 115 VAC +/-10%, 50/60 Hz
- Connected load of 100 W maximum during operation
- Thermal device protection

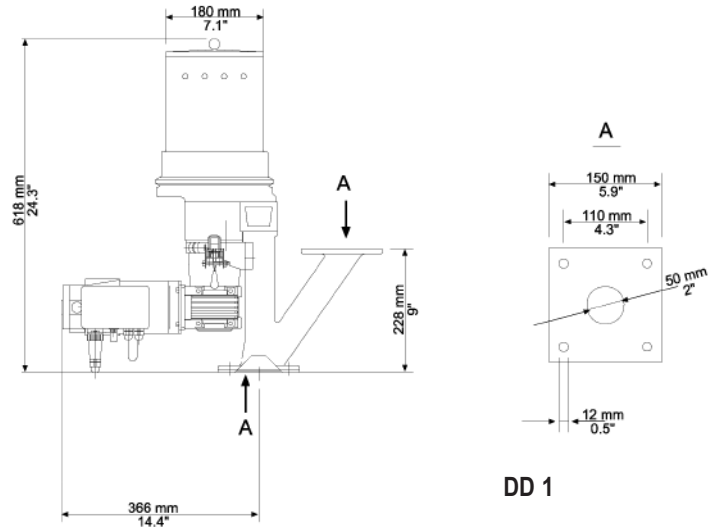

DD 1

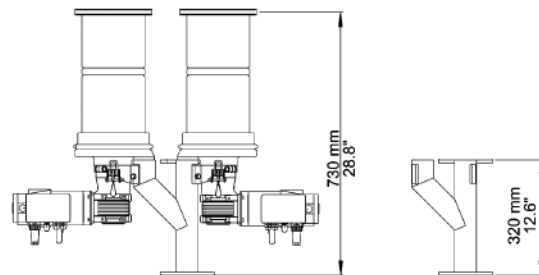

DD 2

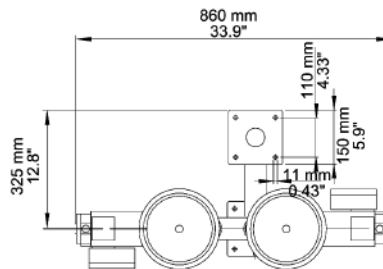



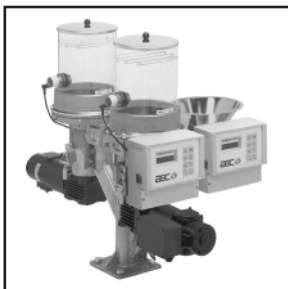

DD 1
Feed Rate: 0.2-800 lbs/hr
Operating Load: 0.2 kW
Weight: 51 lbs. (23kg)



DD 2
Feed Rate: 0.2-800 lbs/hr
Operating Load: 0.4 kW
Weight: 100 lbs. (45kg)

SPECIFICATIONS

Disc	Disc Nomenclature	Min/Max Disc RPM	Amount of Material per Disc Revolution		Minimum Throughput with Continuous Running		Maximum Throughput with Continuous Running	
			35 lbs./ft ³	44 lbs./ft ³	35 lbs./ft ³	44 lbs./ft ³	35 lbs./ft ³	44 lbs./ft ³
 Default calibration # 1.50 g/rev	P030672	0.2 RPM 3.0 RPM	1.53 g/rev 0.02 g/hole	1.95 g/rev 0.027 g/hole	0.04 lb/hr 0.02 kg/hr	0.04 lb/hr 0.02 kg/hr	0.61 lb/hr 0.28 kg/hr	0.77 lb/hr 0.35 kg/hr
	3 mm thick 6 mm dia. 72 pockets CT100562	0.2 RPM 8.4 RPM			0.04 lb/hr 0.02 kg/hr	0.04 lb/hr 0.02 kg/hr	1.69 lb/hr 0.77 kg/hr	2.17 lb/hr 0.98 kg/hr
		0.5 RPM 11.5 RPM			0.10 lb/hr 0.045 kg/hr	0.12 lb/hr 0.05 kg/hr	2.32 lb/hr 1.05 kg/hr	2.89 lb/hr 1.31 kg/hr
		1.0 RPM 38.0 RPM ⁴			0.19 lb/hr 0.09 kg/hr	0.26 lb/hr 0.12 kg/hr	7.66 lb/hr 3.47 kg/hr	9.63 lb/hr 4.37 kg/hr
 Default calibration # 1.30 g/rev	P050660	0.2 RPM 3.0 RPM	1.35 g/rev 0.02 g/hole	1.70 g/rev 0.028 g/hole	0.04 lb/hr 0.02 kg/hr	0.06 lb/hr 0.03 kg/hr	0.42 lb/hr 0.19 kg/hr	0.54 lb/hr 0.24 kg/hr
	5 mm thick 5.7 mm dia. 60 pockets 882.00738.00	0.2 RPM 8.4 RPM			0.05 lb/hr 0.02 kg/hr	0.07 lb/hr 0.03 kg/hr	1.1 lb/hr 0.50 kg/hr	1.37 lb/hr 0.62 kg/hr
		0.5 RPM 11.5 RPM			0.09 lb/hr 0.04 kg/hr	0.10 lb/hr 0.05 kg/hr	1.46 lb/hr 0.66 kg/hr	1.83 lb/hr 0.83 kg/hr
		1.0 RPM 11.5 RPM ⁴			0.17 lb/hr 0.08 kg/hr	0.22 lb/hr 0.10 kg/hr	6.48 lb/hr 2.94 kg/hr	8.54 lb/hr 3.87 kg/hr
 Default calibration # 4.00 g/rev	051040	0.2 RPM 3.0 RPM	4.24 g/rev 0.11 g/hole	5.39 g/rev 0.13 g/hole	0.11 lb/hr 0.05 kg/hr	0.15 lb/hr 0.07 kg/hr	1.68 lb/hr 0.76 kg/hr	2.14 lb/hr 0.97 kg/hr
	5 mm thick 10 mm dia. 40 pockets CT21710	0.2 RPM 8.4 RPM			0.11 lb/hr 0.05 kg/hr	0.15 lb/hr 0.07 kg/hr	4.71 lb/hr 2.12 kg/hr	5.99 lb/hr 2.72 kg/hr
		0.5 RPM 11.5 RPM			0.27 lb/hr 0.12 kg/hr	0.35 lb/hr 0.15 kg/hr	6.33 lb/hr 2.87 kg/hr	8.00 lb/hr 3.62 kg/hr
		1.0 RPM 38.0 RPM ⁴			0.55 lb/hr 0.25 kg/hr	0.70 lb/hr 0.32 kg/hr	21.19 lb/hr 9.61 kg/hr	27.08 lb/hr 12.28 kg/hr
Consult factory - 40 pocket and 35.5 RPM motor for small pellets and coarse powder only								
 Default calibration # 7.30 g/rev	051725	0.2 RPM 3.0 RPM	7.37 g/rev 0.30 g/hole	9.38 g/rev 0.38 g/hole	0.20 lb/hr 0.09 kg/hr	0.24 lb/hr 0.11 kg/hr	2.92 lb/hr 1.32 kg/hr	3.70 lb/hr 1.68 kg/hr
	D5 mm thick 17 mm dia. 25 pockets CT21711	0.2 RPM 8.4 RPM			0.20 lb/hr 0.09 kg/hr	0.24 lb/hr 0.11 kg/hr	8.18 lb/hr 3.71 kg/hr	10.37 lb/hr 4.70 kg/hr
		0.5 RPM 11.5 RPM			0.48 lb/hr 0.22 kg/hr	0.61 lb/hr 0.27 kg/hr	11.0 lb/hr 4.99 kg/hr	14.0 lb/hr 6.36 kg/hr
		1.0 RPM 38 RPM ⁴			1.00 lb/hr 0.44 kg/hr	1.25 lb/hr 0.57 kg/hr	37.04 lb/hr 16.80 kg/hr	47.10 lb/hr 21.36 kg/hr
 Default calibration # 13.50 g/rev	051818	0.2 RPM 3.0 RPM	13.42 g/rev 0.75 g/hole	17.08 g/rev 0.95 g/hole	0.35 lb/hr 0.16 kg/hr	0.44 lb/hr 0.20 kg/hr	5.34 lb/hr 2.42 kg/hr	6.80 lb/hr 3.08 kg/hr
	5 mm thick 18 mm dia. 18 pockets CT23057	0.2 RPM 8.4 RPM			0.35 lb/hr 0.16 kg/hr	0.44 lb/hr 0.20 kg/hr	14.96 lb/hr 6.79 kg/hr	19.03 lb/hr 8.63 kg/hr
		0.5 RPM 11.5 RPM			0.85 lb/hr 0.39 kg/hr	1.12 lb/hr 0.51 kg/hr	19.60 lb/hr 8.89 kg/hr	25.63 lb/hr 11.62 kg/hr
		1.0 RPM 38.0 RPM ⁴			1.76 lb/hr 0.80 kg/hr	2.20 lb/hr 1.00 kg/hr	67.44 lb/hr 30.59 kg/hr	85.90 lb/hr 38.95 kg/hr

Note 1: This guide is to be used for general disc selection for Digital Dosing unit applications. All rates shown are based on continuous throughput of free-flowing materials. Consult factory for regrind, powder and all hard-to-flow materials.









Note 2: Minimum recovery time is one (1) second, and maximum feeder disc revolutions in one screw recovery cycle (injection mode) is 9.5 revolutions. Use proper disc sizing for injection molding applications to ensure proper dispensing of material during the recovery cycle.

Note 3: Feeder should not be sized to run continuously below 15% of maximum speed - use lower RPM motor or disc with smaller pockets.

Note 4: 35.5 and 38 rpm motors can only be used with soft pellets - may not have enough torque to cut hard pellets, i.e. PC, PET, nylon, etc. especially when the shear gets dull.



SPECIFICATIONS

Disc	Disc Nomenclature	Min/Max Disc RPM	Amount of Material per Disc Revolution		Minimum Throughput with Continuous Running		Maximum Throughput with Continuous Running		
			35 lbs./ft ³	44 lbs./ft ³	35 lbs./ft ³	44 lbs./ft ³	35 lbs./ft ³	44 lbs./ft ³	
 DT30-101820 Default calibration # 28.00 g/rev	101820 10 mm thick 18 mm dia. 20 holes CT23056	0.2 RPM	28.0 g/rev	35.6 g/rev	0.75 lbs./hr	1.00 lbs./hr	11.11 lbs./hr	14.10 lbs./hr	
		3.0 RPM			0.34 kg/hr	0.43 kg/hr	5.04 kg/hr	6.40 kg/hr	
		0.2 RPM			8.4 RPM	0.75 lbs./hr	1.00 lbs./hr	31.11 lbs./hr	39.50 lbs./hr
		0.5 RPM			11.5 RPM	0.34 kg/hr	0.43 kg/hr	14.11 kg/hr	17.90 kg/hr
 DT30-102025 "Sure-shot" Default calibration # 33.00 g/rev	P102025 10 mm thick Oval Hole 18 mm x 25 mm 20 holes CT66707	0.2 RPM	33.6 g/rev	42.7 g/rev	0.87 lbs./hr	1.12 lbs./hr	13.10 lbs./hr	16.60 lbs./hr	
		3.0 RPM			0.40 kg/hr	0.50 kg/hr	5.94 kg/hr	7.50 kg/hr	
		0.2 RPM			8.4 RPM	0.87 lbs./hr	1.12 lbs./hr	36.67 lbs./hr	46.60 lbs./hr
		0.5 RPM			11.5 RPM	0.40 kg/hr	0.50 kg/hr	16.63 kg/hr	21.10 kg/hr
 DT30-203012 Default calibration # 95.00 g/rev	203012 20 mm thick 30 mm dia. 12 holes CT23060	0.2 RPM	95.0 g/rev	118.7 g/rev	2.51 lbs./hr	3.13 lbs./hr	37.73 lbs./hr	47.10 lbs./hr	
		3.0 RPM			1.14 kg/hr	1.42 kg/hr	17.11 kg/hr	21.30 kg/hr	
		0.2 RPM			8.4 RPM	2.51 lbs./hr	3.13 lbs./hr	105.66 lbs./hr	131.9 lbs./hr
		0.5 RPM			11.5 RPM	1.14 kg/hr	1.42 kg/hr	47.93 kg/hr	59.80 kg/hr
 DT30-204010F Default calibration # 150.00 g/rev	204010F 20 mm thick 40 mm dia. 10 pockets CT18405	0.2 RPM	151.1 g/rev	188.7 g/rev	4.00 lbs./hr	5.00 lbs./hr	60.00 lbs./hr	75.00 lbs./hr	
		3.0 RPM			1.80 kg/hr	2.25 kg/hr	27.22 kg/hr	34.00 kg/hr	
		0.2 RPM			8.4 RPM	4.00 lbs./hr	5.00 lbs./hr	168.00 lbs./hr	210.00 lbs./hr
		0.5 RPM			11.5 RPM	1.80 kg/hr	2.25 kg/hr	76.20 kg/hr	95.20 kg/hr
 DP30-250940 Default calibration # 7.80 g/rev	P250940 2.5 mm thick 9 mm dia. 40 pockets CT100864	0.2 RPM	7.8 g/rev	9.7 g/rev	0.20 lbs./hr	0.26 lbs./hr	3.07 lbs./hr	3.87 lbs./hr	
		3.0 RPM			0.093 kg/hr	0.115 kg/hr	1.40 kg/hr	1.76 kg/hr	
		0.2 RPM			8.4 RPM	0.20 lbs./hr	0.26 lbs./hr	8.61 lbs./hr	10.83 lbs./hr
		0.5 RPM			11.5 RPM	0.093 kg/hr	0.115 kg/hr	3.91 kg/hr	4.91 kg/hr
 DP30-050940 Default calibration # 15.00 g/rev	P050940 5 mm thick 9 mm dia. 40 pockets CT100863	0.2 RPM	15.6 g/rev	19.5 g/rev	0.41 lbs./hr	0.51 lbs./hr	6.19 lbs./hr	7.73 lbs./hr	
		3.0 RPM			0.187 kg/hr	0.23 kg/hr	2.81 kg/hr	22.26 kg/hr	
		0.2 RPM			8.4 RPM	0.41 lbs./hr	0.51 lbs./hr	17.33 lbs./hr	21.66 lbs./hr
		0.5 RPM			11.5 RPM	0.187 kg/hr	0.23 kg/hr	7.86 kg/hr	9.82 kg/hr
 DP30-050940 Default calibration # 15.00 g/rev	P050940 5 mm thick 9 mm dia. 40 pockets CT100863	1.0 RPM	0.39 g/hole	0.49 g/hole	1.00 lbs./hr	0.12 lbs./hr	22.62 lbs./hr	28.65 lbs./hr	
		38.0 RPM ⁴			0.45 kg/hr	0.57 kg/hr	10.62 kg/hr	13.80 kg/hr	
 DP30-050940 Default calibration # 15.00 g/rev	P050940 5 mm thick 9 mm dia. 40 pockets CT100863	1.0 RPM	0.39 g/hole	0.49 g/hole	2.00 lbs./hr	2.60 lbs./hr	78.57 lbs./hr	98.16 lbs./hr	
		38.0 RPM ⁴			0.94 kg/hr	1.17 kg/hr	35.64 kg/hr	44.52 kg/hr	

Note 1: This guide is to be used for general disc selection for Digital Dosing unit applications. All rates are based on continuous throughput of free-flowing materials. Consult factory for regrind, powder and all hard-to-flow materials.

Note 2: Maximum Minimum recovery time is one (1) second, and maximum feeder disc revolutions in one screw recovery cycle (injection mode) is 9.5 revolutions. Use proper sizing for injection molding applications to ensure proper dispensing of material during the recovery cycle.

