



HARMO HRX-500SWf AND HRX-500GWf

With pinpoint accuracy and repeatability, rugged durability, and high speed performance, the HRXf Series Full Servo Extraction Robots are redefining the automation industry. These powerful yet very cost effective robots are perfect for automating horizontal molding machines from 100-350 tons in both three and five axis configurations.

The HRXf Series features the highest quality linear guides on all axes, employing THK rail and bearing systems. The redesigned kick frame provides more rigidity for enhanced support and repeatability.



STANDARD FEATURES

- All axis AC digital servo actuation-absolute encoder
- Three-dimensional axis movement
- Thick-walled aluminum extrusion traverse beam with steel sub-weldment
- THK linear guide rail with large block bearings (all axes)
- C-Axis 90° wrist flip
- Programmable part extraction from stationary or moving platen
- One (1) part vacuum circuit with detection
- One (1) mechanical circuit with detection
- One (1) sprue grip circuit with detection
- SPI-ready with 32 pin DIN plug

OPTIONAL FEATURES

- Two-stage telescopic vertical arm construction for low overhead environment (standard on HRX-300 and larger robots)
- A-Axis pneumatic two-position 0-90 or 0-180 degree wrist rotation
- Additional pressure and/or vacuum circuit(s)
- Machine platen spacer with custom mounting bolt hole pattern
- EOAT quick-change system (robot & EOAT side)
- Extended stroke lengths (varies by model)
- End of beam support
- EuroMap 12 or 67 IMM interface (SPI interface/plug is standard)
- SPI interface plug kit (10 amp/32 pin) for molding machine side
- Transformer for voltages other than 200-220 VAC/ three phase

SPECIFICATIONS

Model	Vertical Stroke (mm)		Stripe Stroke (mm)		Traverse Stroke (mm)	Max. Payload (kg)	Machine Weight (kg)
	Main	Sub	Main	Sub			
HRX-800SWf	1300(1400)	--	1100	--	2000 (2400)	15 (IncludingEOAT)	473
HRX-800GWf		1300(1400)		1045			

Model	Working Air Pressure (mpa)	Air Consumption (N _l /Cyc) *1	Drive System	Control Method	Power Supply (V)	Power Consumption (W)
HRX-800SWf	0.6	12.5	Digital AC Servo Motor (3/ 5 Axis)	PTP•CP	3P 200 ACV +10%/-15% (50Hz/60Hz)	2800
HRX-800GWf						

*1 Additional 63N_l/min is consumed for each vacuum ejector

DIMENSIONS (MM)

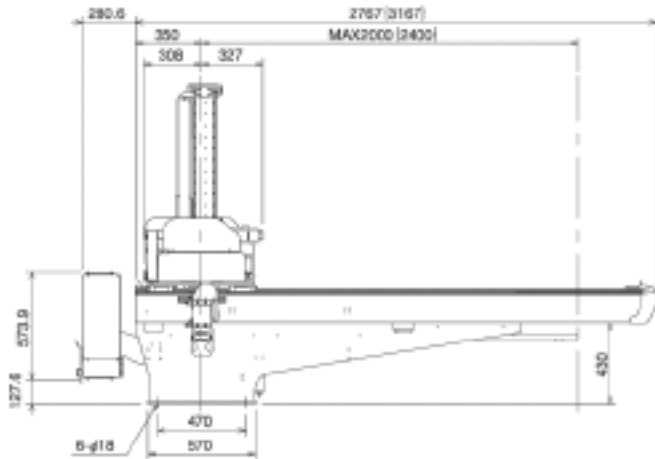

Dimensions in curly brackets are optional.

